

The Effect of Mixed Dye Composition of Anthocyanin-Chlorophyll on DSSC Efficiency on TiO_2/ZnO Semiconductors

Renta Wendi Manurung, Nurhidayah* & Frastica Deswardani

Physics Study Program, University of Jambi, Indonesia

*Corresponding Author: nurhidayah@unja.ac.id

Received: 4th December 2023; Accepted: 15th May 2024; Published: 15th June 2024

DOI: <https://dx.doi.org/10.29303/jpft.v10i1.6192>

Abstract - The effect of mixed dye composition of anthocyanin-chlorophyll on DSSC efficiency on TiO_2/ZnO semiconductors aims to determine the effect of using dye containing anthocyanin-chlorophyll on the absorbance value and work efficiency value of Dye Sensitized Solar Cell (DSSC). The TiO_2/ZnO was deposited using the doctor blade method and the dye was made using the maceration method. The counter electrode was made on FTO glass coated by calcined battery carbon with temperature in 450°C . The DSSC assembly was arranged in a sandwich shape. Then electrolyte is dripped in the middle of the DSSC layer. Characterization tests were carried out to determine the dye absorbance value and gap energy value using a UV-Vis spectrophotometer. DSSC efficiency testing uses current and voltage (I-V) characterization. DSSC testing was carried out using a multimeter with a light source from sunlight. The results of UV-Vis characterization showed that the highest absorbance value was obtained for the kale-mangosteen peel dye at a wavelength of 530 nm with an absorbance of 5.234%. The TiO_2/ZnO gap energy obtained using the touch plot method is 2.42 eV. The highest efficiency value was obtained from the kale-mangosteen peel dye mixture of 0.0286%. There was an increase in the DSSC efficiency value when the dyes were combined.

Keywords: DSSC; TiO_2/ZnO ; Efficiency

INTRODUCTION

In Indonesia, the increasing energy demand is due to population growth and rapid industrial development. One of the most important energy sources is electricity. Excessive use of electricity can lead to a depletion of fossil fuels and environmental issues such as air and water pollution. To mitigate these consequences, renewable and abundant energy sources are needed. One of the abundant energy sources is solar energy. Solar energy can be harnessed as a source of electricity using solar cell devices.

DSSC (Dye Sensitized Solar Cell) is a form of renewable energy that utilizes solar energy. DSSC is an organic solar cell that uses dye to enhance the sensitivity of the solar cell. Solar cells work by converting sunlight directly into electricity using semiconductors and dyes.

TiO_2/ZnO is a semiconductor material used in this study. According to Ramadhika et al. (2021), the combination of

semiconductor materials is expected to utilize the superior properties of both. TiO_2 has a high surface area, while ZnO has high charge carrier mobility (electrons) and absorbance.

Anthocyanin can be used as a dye in DSSC because it can absorb sunlight at a wavelength of around 500 nm (Ramadhanty and Iqbal 2021). The anthocyanin materials used are red onion skins and mangosteen peels. Adu et al. (2022) reported that the DSSC efficiency obtained from red onion skin dye is 0.0491%. Nirmalasari et al. (2022) reported that DSSC efficiency using mangosteen peel dye is 0.0190%.

According to Fistiani et al. (2017), chlorophyll can also be used as a dye in DSSC applications, with absorbance peaks at wavelengths of 420 nm and 660 nm. Fistiani et al. (2017) used anthocyanin

from red cabbage and spinach leaves in DSSC, achieving an efficiency of 0.04%. Agus et al. (2020) used ZnO and TiO_2

semiconductors for DSSC with water spinach dye, achieving the highest efficiency of 0.081%. The combination of anthocyanin and chlorophyll materials is expected to improve efficiency values for better alternative energy sources in the future.

RESEARCH METHODS

Substrate Preparation

FTO (Fluorine Tin Oxide) glass was cut to a size of 2×2 cm. The FTO glass was cleaned by soaking in distilled water for 10 minutes, then soaked in ethanol for 10 minutes, and dried using a hair dryer.

Dye Extraction

The dye materials used are red onion skins, mangosteen peels, spinach leaves, and water spinach leaves. Each dye material was weighed to 40 grams and blended. Each blended dye was soaked in a beaker containing 25 mL of ethanol, 4 mL of acetic acid, and 20 mL of distilled water, and left for 24 hours in a dark place. The dye extract soaked for 24 hours was filtered using a vacuum pump and Buchner funnel to produce the extract. Each dye was used in 20 mL as a single dye. For mixed dyes, 10 mL of red onion skin dye was added to 10 mL of spinach leaf dye, 10 mL of red onion skin dye was added to 10 mL of water spinach leaf dye, 10 mL of mangosteen peel dye was added to 10 mL of spinach leaf dye, and 10 mL of mangosteen peel dye was added to 10 mL of water spinach leaf dye.

Preparation of TiO₂/ZnO Paste

TiO₂/ZnO was used in 278 grams. According to Retnaningsih et al. (2016), the ratio of TiO₂/ZnO used is 20% TiO₂: 80% ZnO. The TiO₂ and ZnO mixture was ground with a mortar for 30 minutes. 0.4 grams of PVA and 8 mL of distilled water were stirred using a hotplate for 60 minutes at 80°C until it formed a gel. The gel and TiO₂/ZnO were

stirred with a mortar for 30 minutes until a paste was formed. The TiO₂/ZnO was then deposited on FTO glass using the doctor blade technique. The thin layer was left in open air for 10 minutes and then heated using an oven at 120°C for 10 minutes.

Electrolyte Preparation

0.83 grams of potassium iodide (KI) and 10 mL of acetonitrile were stirred using a hotplate for 10 minutes at room temperature. Then, 0.127 grams of iodine were added and stirred again using a hotplate for 30 minutes. The solution was stored in a dark glass bottle.

Counter Electrode Preparation

FTO glass and battery carbon were prepared. The carbon was ground with a mortar until smooth. 0.5 grams of PVA and 45 mL of distilled water were stirred using a hotplate at 80°C. The gel was mixed with the carbon in a mortar and stirred until well blended. The FTO glass was coated with carbon and then heated at 450°C for 15 minutes (Maryani Gunawan & Khabibi 2012).

DSSC Assembly

The counter electrode was placed on a flat surface with the carbon-coated surface facing up. The FTO substrate coated with TiO₂/ZnO was placed on top with the TiO₂/ZnO layer facing down. The two glass layers were clamped using paper clips. Electrolyte solution was dripped on the side between the TiO₂/ZnO layer and the counter electrode.

Characterization and Testing

Each dye was characterized using a UV-Vis spectrophotometer to determine the absorbance value of the dye. The gap energy value of the TiO₂/ZnO semiconductor was determined using a UV-Vis

spectrophotometer with transmission data. DSSC testing was conducted under sunlight using a multimeter. The tests measured current and voltage. The DSSC was arranged as shown in Figure 1.

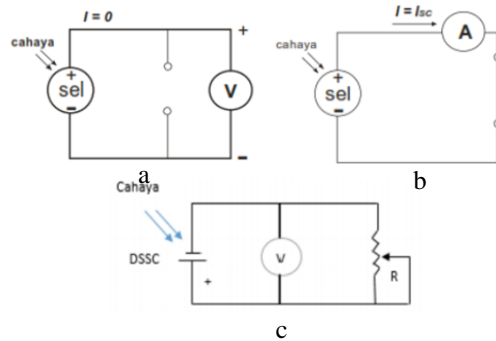

Figure 1. Schematic diagram of measurement circuits: (a) open-circuit voltage (V_{oc}), (b) short-circuit current (I_{sc}), (c) schematic diagram of V_{max} and I_{max} measurement circuits for DSSC (Prayogo et al. 2014)

The formula used to determine the efficiency value is:

$$FF = \frac{J_{max} \times V_{max}}{J_{sc} \times V_{oc}} \quad (1)$$

$$P_{out} = J_{sc} \times V_{oc} \times FF \quad (2)$$

$$\eta = \frac{P_{out}}{P_{in}} \times 100\% \quad (3)$$

Note:

FF = Fill factor

J_{max} = Maximum current density (mA/cm²)

V_{max} = Maximum voltage (V)

J_{sc} = Short-circuit current density (mA/cm²)

V_{oc} = Open-circuit voltage (V)

P_{out} = Output power (mW/cm²)

P_{in} = Input power (mW/cm²)

η = DSSC efficiency (%)

RESULTS AND DISCUSSION

Results

1. Dye Absorbance

UV-Vis spectrophotometer testing on dyes aims to determine the absorbance of single and mixed dyes at wavelengths of 200-800 nm. The test results are shown in Figures 2 and 3.

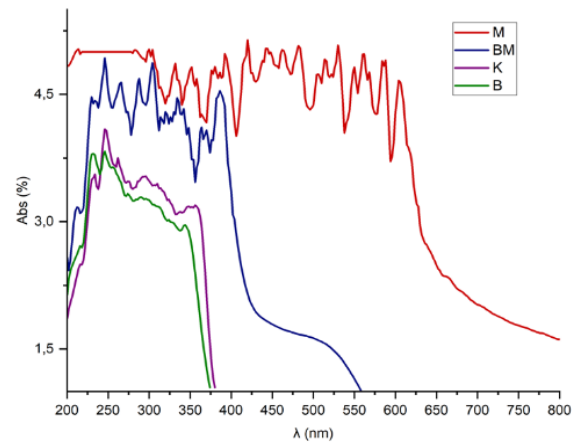

Figure 2. Absorbance curve of single dyes

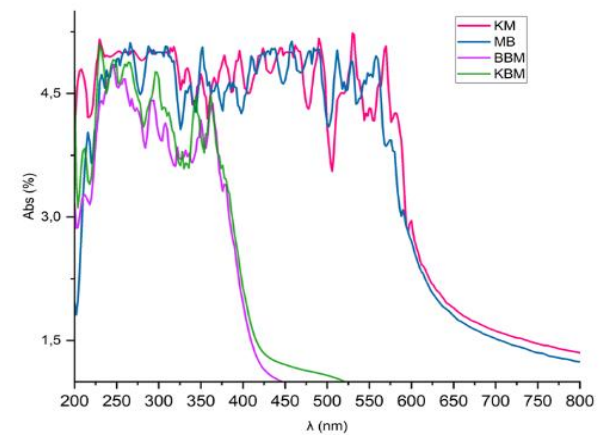

Figure 3. Absorbance curve of mixed dyes

*Note: Mangosteen peel (M), red onion skin (BM), water spinach leaves (K), spinach leaves (B), mangosteen peel + water spinach leaves (KM), mangosteen peel + spinach leaves (MB), red onion skin + water spinach leaves (KBM), red onion skin + spinach leaves (BBM).

Figure 2 shows the absorbance values of single dyes. Mangosteen peel has a maximum peak at a wavelength of 422 nm with an absorbance of 49.71%. Red onion skin has a maximum peak at a wavelength of 246 nm with an absorbance of 49.29%. Spinach leaves have a maximum absorption peak at a wavelength of 248 nm with an absorbance of 37.61%. Water spinach leaves have a maximum absorption peak at a wavelength of 246 nm with an absorbance of 36.15%.

Figure 3 shows the absorbance values of mixed dyes. Mangosteen peel + spinach leaves have a maximum peak at a wavelength of 248 nm with an absorbance of 53.86%. Red onion skin + spinach leaves

have a maximum peak at a wavelength of 226 nm with an absorbance of 41.44%. Red onion skin + water spinach leaves have a maximum peak at a wavelength of 246 nm with an absorbance of 50.55%. Mangosteen peel + water spinach leaves have a maximum peak at a wavelength of 530 nm with an absorbance of 5.234%. Based on Figures 2 and 3, it can be seen that the dyes with the highest absorbance values are red onion skin + water spinach leaves at 530 nm with an absorbance of 5.234%.

Energy Gap Value TiO₂/ZnO

UV-Vis spectrophotometer testing on TiO₂/ZnO aims to determine the energy gap value in TiO₂/ZnO semiconductors using transmission data. The energy gap value is calculated using the Swaneupol equation and the touch plot method. According to Rahman et al. (2019), the energy gap value for TiO₂ is 3.2 eV, and according to Alfarisa (2018), the energy gap value for ZnO is 3.37 eV. The energy gap value obtained, based on Figure 4, is 2.42 eV.

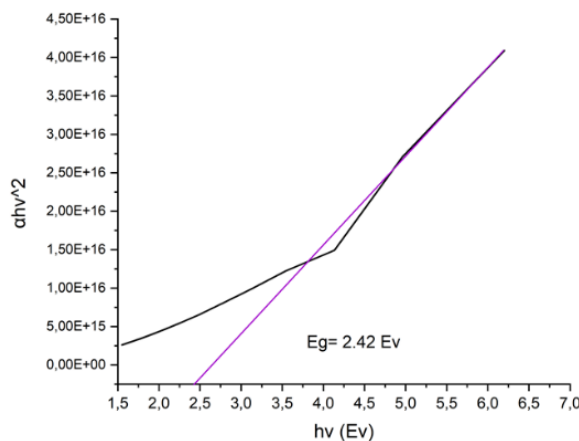

Figure 4. TiO₂/ZnO Energy Gap Value using touch plot method

Current (I) and Voltage (V) Testing

Current and voltage testing is conducted under sunlight to obtain efficiency values as per Equations 1, 2, and 3. Table 1 shows the efficiency values of DSSC.

Table 1. Efficiency Values of DSSC

No.	Dye Composition	V _{max} (V)	I _{max} (mA)	η (%)
1.	BM	0,887	0,00709	0,00344
2.	M	1,262	0,0101	0,00697
3.	K	0,182	0,01213	0,00120
4.	B	0,0701	0,01402	0,00053
5.	KM	0,8871	0,05914	0,02867
6.	MB	0,4712	0,0942	0,02427
7.	BBM	0,5706	0,03804	0,01186
8.	KBM	0,34	0,0694	0,01316

*Note: Mangosteen peel (M), red onion skin (BM), water spinach leaves (K), spinach leaves (B), mangosteen peel + water spinach leaves (KM), mangosteen peel + spinach leaves (MB), red onion skin + water spinach leaves (KBM), red onion skin + spinach leaves (BBM).

Discussion

Based on Figure 2, mangosteen peel has an absorbance in ultraviolet and visible light with a wavelength range of 200-800 nm. The absorbance values obtained differ slightly from previous studies on mangosteen peel dye, which showed a range of 300-800 nm (Motlan et al., 2021). Red onion skin has an absorbance range of 200-390 nm. The absorbance value of red onion skin dye is lower compared to mangosteen peel dye. The absorbance value of red onion skin dye obtained is similar to previous studies, which showed a range of 200-370 nm (Adu et al., 2022). Spinach dye has a smaller absorbance compared to water spinach dye, with a range of 230-374 nm. The absorbance values are almost similar to previous studies, which showed a range of 200-400 nm (Puspitasari et al., 2017). Water spinach dye has an absorbance range of 216-380 nm. The wavelength range obtained differs from previous studies (Fistiani et al., 2017). Anthocyanin dye has a wider absorbance range compared to chlorophyll dye, as anthocyanin can absorb light over a broad range (Nirmalasari et al., 2022).

Based on Figure 3, water spinach and red onion skin dyes have a maximum absorbance at a wavelength of 232 nm. Spinach and red onion skin dyes have a

maximum absorbance at a wavelength of 246 nm. The absorbance range of red onion skin dye is larger compared to its combination with chlorophyll, but the absorbance value of the red onion skin and chlorophyll combination is higher than that of the single red onion skin dye. It can also be seen that the absorbance range of chlorophyll dyes, when combined with water spinach and spinach dyes, is larger compared to single chlorophyll dyes.

It can be observed that the combination of mangosteen peel-water spinach, mangosteen peel-spinach, red onion skin-water spinach, and red onion skin-spinach dyes shows an increase in wavelength range compared to single dye usage. Among the four dye combinations, the mixture of water spinach and mangosteen peel has the highest absorbance wavelength range.

Based on Table 1, the efficiency value of single dyes is lower than that of combined dyes. The efficiency value increases when anthocyanin and chlorophyll dyes are combined, as this leads to better photon absorption in the samples. The highest efficiency value is achieved by the water spinach-mangosteen peel dye combination, while the lowest efficiency value is achieved by the spinach dye. According to Manurung et al. (2021), the value of single dyes is directly proportional to the increased efficiency value of mixed dyes. The higher the anthocyanin and chlorophyll content in a sample, the more photon energy is absorbed, resulting in more electron movement and an electron flow that can be converted into electric current (Listari and Agustini, 2018).

CONCLUSION

The absorbance and efficiency values of DSSC increase after mixing anthocyanin-chlorophyll dyes. The dye with the highest absorbance is the combination of water

spinach and mangosteen peel dyes, with an absorbance value of 5.234% and an efficiency of 0.0286%. Future studies are expected to explore other dye combinations to determine DSSC efficiency and improve DSSC structure for better performance and efficiency.

REFERENCES

- Adu, R. E. Y., G. Gelyaman & M. Kabosu. (2022). Pemanfaatan Ekstrak Antosianin Dari Limbah Kulit Bawang Merah (*Alium cepa*) Sebagai Zat Pemeka (Sensitizer) Pada *Dye Sensitized Sollar Cell* (DSSC). *ALCHEMY Jurnal Penelitian Kimia*, 18(1), 103-111.
- Agus, S., D. Kurniawan & C. Cari. (2020). Pengaruh perbandingan komposisi ZnO dan TiO₂ dalam *Dye sensitized solar cell* (DSSC) pada dye kangkung (*impoema aquatica*). *Prosiding seminar nasional fisika dan aplikasinya*.
- Alfarisa, S., D. A. Rifai & P. L. Toruan. (2018). Studi difraksi sinar-x struktur nano seng oksida (ZnO). *Risalah Fisika*, 2(2), 53-57.
- Fistiani, M. D., F. Nurosyid & R. Suryana. (2017). Pengaruh komposisi campuran antosianin-klorofil sebagai fotosensitizer terhadap efisiensi *dye sensitized solar cell*. *Jurnal fisika dan aplikasinya*, 13(1), 19-22.
- Listari, N., & D. Agustini. 2018. Daun Pegagan (*centella asiatica*) dan kangkung (*ipomea aquatica*) sebagai fotosensitizer pada *dye sensitized solar cell* (DSSC). *Jurnal Pendidikan Biologi dan Sains*, 3(2).
- Manurung, D. N., Nurhidayah & F. Deswardani. 2021. Pengaruh penggunaan *dye* tunggal dan *dye* campuran antosianin-klorofil terhadap efisiensi kerja *dye sensitized solar cell* (DSSC). *Jurnal Pendidikan Fisika Tadulako Online*,

- 9(1):83-88.
- Maryani, D., Gunawan & Khabibi. (2012). Penentuan efisiensi DSSC (*Dye Sensitized Solar Cell*) yang dibuat dari semikonduktor ZnO yang diemban Fe^{3+} melalui metode presipitasi. *Jurnal Kimia Sains dan Aplikasi*, 15(1), 29-35.
- Motlan, D. Ferdinand & N. Siregar. (2021). *Dye sensitized solar cell* (DSSC) menggunakan film tipis ZnO:Mg dengan *dye* ekstrak kulit manggis. *Jurnal Einstein*, 9(2), 51-54.
- Nirmalasari, I., R. A. Nugrahani & Budiyo. (2022). Peningkatan efisiensi *dye sensitized solar cell* (DSSC) dari antosianin kulit manggis (*Garcinia magostana*) menggunakan papain. *Chimica et Natura Acta*, 10(2), 88-93.
- Prayogo, A. F., S.H. Pramono, E. Maulana. (2014). Pengujian dan Analisis Performansi *Dye Sensitized Solar Cell* (DSSC) terhadap Cahaya. *Jurnal Mahasiswa TEUB*, 1(4).
- Puspitasari, N., S. R. Adawiyah, M. N. Fajar, G. Yudoyono, A. Rubiyanto & Endarko. (2017). Pengaruh jenis katalis pada elektroda pembanding terhadap efisiensi *dye sensitized solar cell* dengan klorofil sebagai *dye sensitizer*. *Jurnal fisika dan aplikasinya*, 13(1), 30-33.
- Rahman, F. H., M. Rokhmat & E. Wibowo. (2019). Pembuatan sel surya berbahan TiO₂ dengan penyisipan partikel emas menggunakan metode electroplating. *E-proceeding of engineering*, 6(1), 1165-1172.
- Ramadhanty, A. R., & Iqbal. (2021). Analisa Kualitas Klorofil dan Absorbansi Daun Jarak Merah (*Jatropha Gossypifolia L.*) dan Daun Biduri (*Calotropis Gigantea*) Sebagai Bahan Pewarna Pada *Dye Sensitized Solar Cell* (DSSC). *Gravitasi*, 20(2), 47-50.
- Ramadhika, L., A. Aprilia & L. Safriani. (2021). Studi preparasi senyawa ZnO:TiO₂ sebagai material fotokatalis. *Jurnal material dan energi Indonesia*, 11(2), 83-95.
- Retnaningsih, L., L. Muliani & P. N. Anggraini. (2016). Analisis hasil sintesis serbuk TiO₂/ZnO sebagai lapisan elektroda untuk aplikasi *Dye-sensitized solar cell*. *Jurnal elektronika dan telekomunikasi*, 5(2), 55-59.