

Design and Analysis of an FTTH-GPON in a Residential Area

Rima Fitria Adiati^{1*}, Apriani Kusumawardhani² & Heru Setijono²

¹Department of Physics, Faculty of Mathematics and Natural Sciences, IPB University, Indonesia

²Department of Engineering Physics, Faculty of Industrial Technology and System Engineering, Institut Teknologi Sepuluh Nopember, Indonesia

*Corresponding Author: rima_adiati@apps.ipb.ac.id

Received: 17 October 2022; **Accepted:** 1 December 2022; **Published:** 23 December 2022

DOI: <http://dx.doi.org/10.29303/jpft.v8i2.4233>

Abstract - FTTH design is a crucial step to ensure the best performance of the optical link. In this paper, an FTTH-GPON network is designed, and its performance is analyzed using an optical link power and rise time budget. In the residence of 254 users, at least eight feeder cable cores are needed, with respective ODCs and ODPs. The design satisfies the link power budget with the lowest power margin of 2.469 dB/2.826 dB upstream/downstream in its furthest distance. The highest rise time for the system is 0,2236 ns. The FTTH configuration satisfies ITU-T G.984.1 GPON standard.

Keywords: FTTH; GPON; Link power budget; Rise time budget; Fiber optics

INTRODUCTION

To satisfy the ever-growing need for internet connection, the network providers continuously increase their reach to the deepest and furthest parts of a country, using fixed and mobile networks. The fixed broadband technology had its peak while optical fibers were developed, creating an entirely new communication process. Fiber To The Home (FTTH) is a new optical fiber link configuration trend to bring data transmission straight to our homes. Based on passive optical network technology, it can be implemented from a further distance and carry a higher bandwidth than the conventional copper network. FTTH offers a range of entertainment in a single fiber cable, i.e., voice, data, and video (triple play) while being "future-proof" (Ridho et al., 2020). It supports easy configuration and future enlargement of a network.

The employment of optical fiber cables in any area is challenging work. A lot of design and calculation is necessary to ensure the quality of service and network performance. According to cases reported to the Federal Communication Commission (FCC), more than one-third of service disruptions are due

to fiber optic cable problems (Ab-Rahman et al., 2022). Two categories of network failures exist in a Passive Optical Network (PON) system. The first is a link failure, and the other is a node failure. Link failure refers to the fiber disconnection occurring between components. Some detection and system, however, has been developed to automatically switch the leading network to a secondary one during link failure (Ab-Rahman et al., 2022). Therefore, the protection and restoration of an FTTH network must be considered during the design process. For protection, one needs to employ redundant fibers and splitters. This paper will consider redundant fibers and connection slots during FTTH design.

Previous works (Fahmi et al., 2018; Santika et al., 2016; Ulfawaty & Fausiah, 2019; Utami et al., 2022) show the steps in designing FTTH networks in both rural and urban areas. The simulation method can also be utilized to analyze the performance of FTTH devices (Awalia & Pantjawati, 2018). Because of the flexibility of the Gigabit-PON (GPON) network, multiple configurations can be applied to the same problems (Jamal et al., 2021). The only other consideration might be the cost of materials.

In fact, for areas occupied by both residential customers and businesses, GPON is the most cost-efficient solution (Abdellaoui et al., 2021).

In this paper, an FTTH network is designed for rural residents. The number of users and distances from the nearest communication station are considered. The actual performance of the network is then analyzed to find the prospect of the network to be deployed.

RESEARCH METHODS

GPON and FTTH Optical Networks

Fiber to The Home (FTTH) is a type of optical network, which refers to the deployment of optical fiber from a central office switch directly into a home (Keiser, 2006). The O/E (optical to electrical data conversion) is located in the user's premises or SDU (single dwelling unit). FTTH is one of many FTTX alternatives, some of them are Fiber To The Building (FTTB), Fiber To The Curb (FTTC), Fiber To The Tower (FTTT), or Fiber To The Zone (FTTZ). Of late, a new branch called FTTW which stands for Fiber To The Wireless is also added (Sugumaran et al., 2021).

FTTH is based on Passive Optical Network (PON)(ITU-T, 2005), an optical network architecture where there are no active components between the central office and the customer's premises, in contrast to conventional networks. A PON architecture is based on a shared point-to-multipoint architecture with one or two wavelengths in the downstream direction and one wavelength in the upstream. In other words, optical signal passes through passive elements only, which are fiber optics and splitter/combiner. PON is a third-generation of the optical network after point-to-point fiber and Active Optical Network (AON), where an optical switch is needed.

Since introduced by British Telecom in 1987, PON has been growing continuously due to its flexibility. From the increasing data rate, there are Broadband PON (BPON), Ethernet PON (EPON), and Gigabit PON (GPON), the basis of FTTH networks which operates at 2.5G/1.25G DS/US (i.e., downstream/upstream). The standardization of PON architectures was developed by the International Telecommunication Union Telecommunication Standardization Sector (ITU-T) and Institute of Electrical and Electronic Engineers (IEEE) (Bakarman et al., 2021). GPON design should fulfill ITU-T G. 984.1 recommendation.(ITU-T, 2008)

Recently, new PON standards have been approved by both the ITU-T and the IEEE to increase toward 10 Gb/s speed and beyond: XG-PON operating at 10G/2.5G, symmetrical XGS-PON operating at 10G/10G DS/US, 10G-EPON and NG-PON2.5 (Hernandez et al., 2019). the higher capacity of PON, more wavelength and transmission schematics will be needed. Besides the data rate, PON differentiates the data sharing process, which are TDM-PON (Time Division Multiplexing), WDM-PON (Wavelength Division Multiplexing), and Hybrid-PON. GPON itself uses the TDM technique(Tarigan et al., 2022). Topology of the PON can be distinguished into tree, bus, or ring.

FTTH Components

The general components of FTTH are Optical Line Terminal (OLT), Optical Network Unit (ONU) or Optical Network Termination (ONT), and the fiber link. OLT has the electrical-to-optical (E/O) device, which is directly connected to the metro-ethernet (backbone, or the larger network) in central office. In other words, this is where the binary data signal is converted to light pulses to propagate along the fiber optics.

OLT consists of transceivers, photodetection modules, modulators, and data recovery modules (Keiser, 2006). The Optical Network Unit (ONU) or Optical Network Termination (ONT), is the O/E device located in the user’s premises. OLT and ONT are connected with optical fibers, which are also called Optical Distribution Networks (ODN).

ODN consists of fibers and splitters. Splitters are located in specially-designed cabinets or enclosures to protect the connections from the outside environment. Inside the closure, there are splitters, splices, connectors, and cable management sites. There are 4 segments of ODN:

- Segment 1: feeder cables, connecting OLT to Optical Distribution Cabinet (ODC). Feeder cables usually very large with up to 288 cores
- Segment 2: distribution cable, connecting ODC to Optical Distribution Point (ODP). ODC and ODP are the locations of 1:4 or 1:8 splitter and connectors
- Segment 3: drop cables, connecting ODP to Optical Network Termination (ONT)
- Segment 4: indoor cable, sometimes a single-core cable is needed to connect ONT to Optical Indoor Outlet, or roset. Roset directly connects to the router which provides internet to the user through a LAN cable or wireless connection.

This network architecture is considered the deepest penetration of the fiber optics infrastructure and is the costliest to implement (Keiser, 2003).

Performance Analysis

To evaluate the performance of an optical network, there are some methods, such as optical link power budget, rise time budget, dynamic range, eye diagram, signal to noise ratio, bit error rate, and BL-product.

Some other parameter is observed purely from the user’s perspective or known as Quality of Service (QoS) which includes latency, jitter, packet loss dan throughput (Nofrizal et al., 2022). In the current research, link power budget and rise time budget analysis are conducted.

Link Power Budget Calculation

One most important consideration in designing an FTTH access is the link power budget. Link power budget is a procedure in which one calculates how much power can be lost between the transmitter and the receiver for given receiver sensitivity and transmitter power output. The resulting budget is allocated to connector losses, splice losses, fiber losses, and a safety margin (system margin). The calculation is shown in equations 1 to 3 (Keiser, 2003).

$$\alpha_t = L \times \alpha_f + N_c \times \alpha_c + N_s \times \alpha_s + \alpha_{sp} \quad (1)$$

$$P_{Rx} = P_T - \alpha_t - SM \quad (2)$$

$$M = P_{Rx} - P_R \quad (3)$$

with,

- α_t : total loss (dB)
- L : fiber length (km)
- α_f : optical fiber attenuation (dB/km)
- N_c : number of connectors
- α_c : connector loss (dB)
- N_s : number of splices
- α_s : splice loss (dB)
- α_{sp} : splitter loss (dB)
- P_{Rx} : received power (dBm)
- P_R : receiver sensitivity (dB)
- P_T : transmitter power (dBm)
- SM : safety margin (dB)
- M : power margin (dB)

Rise-time Budget Calculation

A rise-time budget analysis is a convenient method of determining the information capacity of an optical link, especially for a digital links where the capacity is limited by dispersion (Keiser,

2006). Every active element in the optical link has its own rise and down-time, while passive element such as the optical fiber has material and intermodal dispersion. The rise time budget analysis becomes necessary to guarantee the FTTH system is able to deliver information with the proposed bandwidth and bit rate, despite the effect of pulse degradation.

Table 1. Components contributing to pulse rise-time degradation.

Rise time components in eq. 7	Remarks	Typical Values
t_{TX} Transmitter rise time	The time it takes the light source power to increase from the 10 percent to the 90 percent point.	0.2 ns for an LED and 0.1 ns for a laser diode source
t_{mod} Modal dispersion	Caused by different group velocity for each mode	For singlemode fibers, t _{mod} = 0
t_{CD} Chromatic dispersion	t _{CD} ≈ D _{CD} L Δλ where Δλ is spectral width of light source in nm, L is fiber length, and D _{CD} is fiber chromatic dispersion	D ₁₅₅₀ = 17 ps/(nm.km) D ₁₃₁₀ = 3.56 ps/(nm.km) for G.652.D optical fiber (ITU-T, 2016) Δλ = 1 nm for laser diode source
t_{PMD} Polarization mode dispersion	t _{PMD} = D _{PMD} × √fiber length where D _{PMD} is the polarization mode dispersion measured in units of ps√km	D _{PMD} = 0.2 ps√km for G.652.D optical fiber
t_{RX} Receiver rise time	t _{RX} = 0.7/BW The time it takes the detector output to increase from the 10 percent to the 90 percent point.	0.05–0.5 ns for InGaAs pin photodiode 0.1–0.5 ns for InGaAs avalanche photodiode

The total pulse dispersion must not exceed the bandwidth capacity or some data will be lost. In general, the total time

degradation of the system t_{sys} should not exceed 70% of bit period for the NRZ system or 35% of bit period for the RZ system. One bit period is defined as the reciprocal of bandwidth.

$$t_{sys} \leq \frac{0.7}{BW} ; \text{NRZ (non-return-to-zero)} \quad (4)$$

$$t_{sys} \leq \frac{0.35}{BW} ; \text{RZ (return-to-zero)} \quad (5)$$

The total rise time t_{sys} of the link is the root-sum-square calculation of the rise times from each contributor t_i to the pulse rise-time degradation, shown in eq. 6 (Keiser, 2006).

$$t_{sys} = (\sum_{i=1}^N t_i^2)^{\frac{1}{2}} \quad (6)$$

In an FTTH system, the components that contribute to pulse rise-time degradation are the transmitter, fiber dispersions, and receiver. During the signal propagation inside the fiber, the signal undergoes modal dispersion, chromatic dispersion, and polarization mode dispersion. These values substituted to eq. 6 so the total rise time can be expressed as follows:

$$t_{sys} = \sqrt{t_{TX}^2 + t_{mod}^2 + t_{CD}^2 + t_{PMD}^2 + t_{RX}^2} \quad (7)$$

The remarks of notation and typical values are shown in Table 1.

RESULTS AND DISCUSSION

Design of FTTH Network in Residential Area

Pesona Alam Dramaga is a residential area currently being developed in rural areas of Bogor, Indonesia. Figure 1 shows the aerial image of the residence, where the area of interest is about 500 meters from the main provincial road. Current progress indicates that only some houses finished being built in C and E blocks. Therefore, the scope of design is for those blocks, comprising 254 houses, shown more clearly in figure 2. The design and planning depicted in this research are for future use, by calculating the number of houses and listing them in groups of

ODPs, where minimum use of materials is expected.

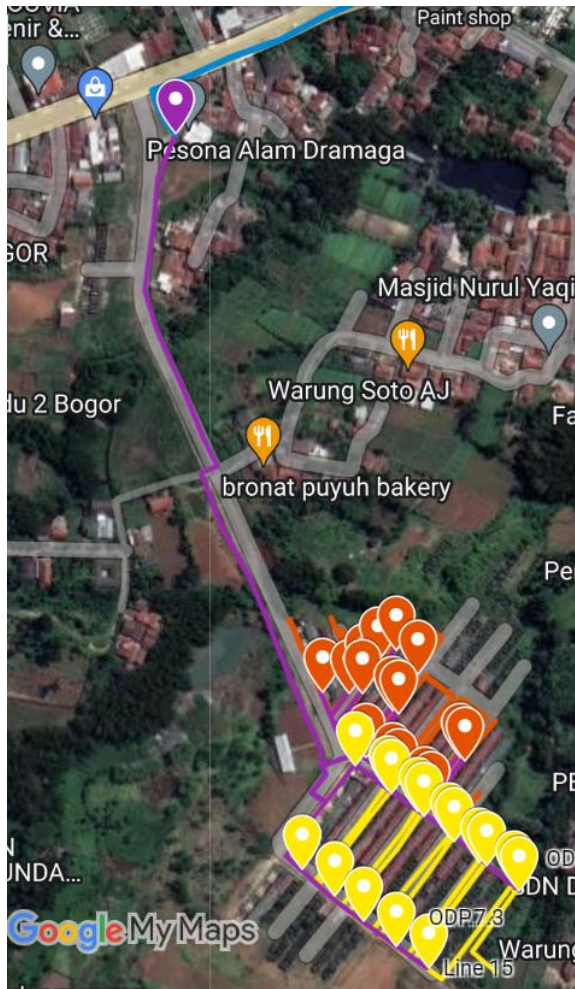

Figure 1. The satellite imagery of Pesona Alam Dramaga Residence, and FTTH components are denoted in different colors.

In figure 1 and 2, it is shown the FTTH component with different colors. The blue line is a feeder cable, connecting ODC to the nearest communication station where OLT is located, about 6,406 km from the ODC. The purple marker is ODC, and the purple line is the distribution cable, connecting ODC and ODP. The red markers are 16 ODPs in C blocks, while yellow marker shows 16 ODPs in E blocks. Red and Yellow lines are all drop cables, which bring the transmission directly to each house. The ONT is not shown in this figure.

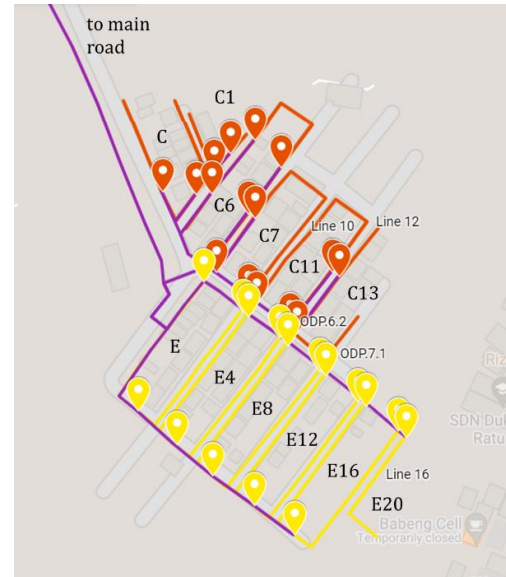

Figure 2. ODP configuration in a residence

The houses of E and C blocks are grouped into ODPs with max 8 users (houses) for 1 ODP since the ODP supports 1:4 or 1:8 optical fiber splitting. There are 32 ODPs with a maximum capacity of 256 users. Meanwhile, in the ODC, there are 8 splitters 1:4, so the total feeder cable necessary from the OLT is 8 cores. The proposed configuration is displayed in figure 3.

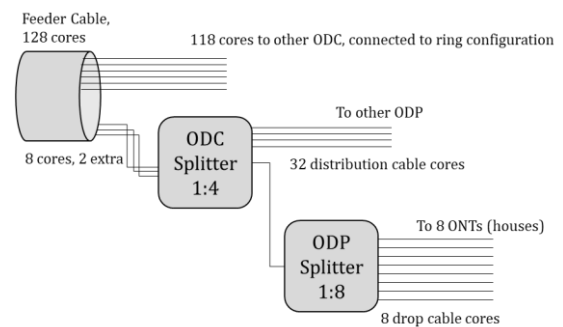

Figure 3. Proposed FTTH architecture

Link Power Budget Analysis

For short-haul GPON links such as FTTH, the losses calculation only consists of passive elements, with a typical safety margin of 6 dB. The transmitter (laser or LED) power and receiver sensitivity depend on the OLT/ONT specification, which in this design, is proposed to be 3 dBm and -28

dBm, consecutively. Table 2 shows an example of a complete calculation for downstream transmission in one user with the nearest distance from ODP. Notice that the drop cable is only 2 meters (0,002 km) in length.

Table 2. Example of Link Power Budget calculation for nearest user from ODP 2.2

Loss Parameter	fiber length / num of	Loss	Loss Unit	Total loss of parameter
OLT - ODC				
Feeder cable	6,406	0,35	dB/km	2,242
Splice loss	6	0,1	dB	0,6
Connector loss	1	0,25	dB	0,25
ODC - ODP				
Distribution cable	0,539	0,35	dB/km	0,189
Splice loss	2	0,1	dB	0,2
Connector loss	2	0,25	dB	0,5
Splitter 1:4	1	7,25	dB	7,25
ODP-ONT				
Drop cable	0,002	0,35	dB/km	0,001
Connector loss	2	0,25	dB	0,5
Splitter 1:8	1	10,38	dB	10,38
Total Loss				22,111
Link power budget calculation				
Transmitter power, P_t	3		dBm	
Receiver sensitivity, P_r	-28		dBm	
Total loss, a		22,111	dB	
Safety margin, SM	6		dB	
Received power, $P_{rx} = P_t - a - SM$		-25,111	dB	
Power margin, $M = P_{rx} - P_r$		2,889	dB	Acceptable

From table 2, it is shown that the total link loss is 22,111 dB. It is well below the maximum loss of 28 dB for a commonly-used class C GPON FTTH. Using the link power budget analysis, it is calculated that the power margin is 2,889 dB, acceptable since the standard margin requirement is $M \geq 0$. It would mean that there is 2,889 dB of spare power to overcome any more losses.

The length of fiber between ODC-ODP (distribution cable) and ODP-ONT (drop cable) needs to be adjusted for each user based on the home position inside the residence. Its needs to be addressed that table 2 includes the fiber loss of 3,5 dB/km, which is different at downstream and upstream. The fiber loss values for upstream

transmission should be 0,4 dB/km, following ITU-T G.652.D fiber data. The difference in fiber loss is caused by the usage of different wavelengths. The downstream data send by 1550 nm light pulses, while upstream data uses 1310 nm. Different wavelength configuration is also possible to be used, such as 1490 nm for downstream, 1310 for upstream, and separate 1550 nm wavelength for video or radio overlay, which will not be discussed in this paper.

Table 3 shows the results of link power budget analysis for downstream and upstream transmissions. The nearest distance means that the user ONTs, in this case, the house is located very near the ODP, which could be both aerial or ground box. The distance is noted by the cable length between ODP to the user's ONT. The min and max values show the extreme ends of the group included in the min and max distance.

The parameters shown are total loss (α_t) and power margin (M). The lower the total loss, the better the transmission performance, and so forth. On the opposite, the higher power margin available, the more versatile and protected the link be. More on network protection is explained in section 3.4.

Table 3 shows min and max total loss and power margin in downstream and upstream. It is observed that both for upstream and downstream transmission, there is not many discrepancies between the nearest and furthest distance (less than 0.1 dB). This shows that FTTH with a distance about 6 km from the OLT is highly acceptable.

It is noted that the maximum link loss in the nearest distance is lower than the furthest distance because the loss is affected by fiber length. Meanwhile, the splice loss, connector loss, and splitter loss are identical for each user. The maximum power margin in the downstream transmission is higher

than upstream transmission as an effect of higher fiber loss. Overall, both the power margin and maximum optical loss are acceptable in all users based on FTTH standards.

Table 3. Link Power Budget Results

		Downstream		Upstream	
		min	max	min	max
Nearest Distance	Total Loss	22.092	22.151	22.436	22.504
	Power Margin	2.849	2.909	2.496	2.564
Furthest Distance		min	max	min	max
		Total Loss	22.107	22.174	22.454
	Power Margin	2.826	2.893	2.469	2.546

Rise Time Budget Analysis

The rise time budget analysis is implemented in the designed FTTH network. The rise time calculated is for the minimum and maximum distances in both downstream and upstream transmissions. The parameter used is shown in table y. For GPON links with NRZ format, the maximum data rate based on ITU-T standards is 1,25 Gbps for upstream, and 2,5 Gbps for downstream transmission. From equation 3, the maximum rise time can be calculated as follows, which results in the allowed rise time budget being 0,56 ns and 0,28 ns for upstream and downstream transmission, respectively.

$$t_{sys} \text{ (upstream)} \leq \frac{0.7}{1,25 \times 10^9} ; \text{ and}$$

$$t_{sys} \text{ (downstream)} \leq \frac{0.7}{2,5 \times 10^9} ; \text{ so}$$

$$t_{sys} \text{ (upstream)} \leq 0,56 \times 10^{-9} \text{ seconds}$$

$$t_{sys} \text{ (downstream)} \leq 0,28 \times 10^{-9} \text{ seconds}$$

The parameters for rise time calculation are shown in table 4, while the result is viewed in table 5. It can be concluded that the FTTH design will be able to handle the data rate up to 2,5 Gbps, especially in the OLT-ODC segment which transmits data for all users. The upstream

generally has a lower data stream, hence the lower standard of rise time. It also considers the ONT specification which is generally lower than OLT, because it only handles the data transfer at the end user and covers a small area, in FTTH case, a home.

Table 4. Parameters used in rise time budget analysis

Parameters		
t_{TX}	100	ps
t_{RX}	200	ps
$D_{CD,1550}$	17	ps/(nm.km)
$D_{CD,1310}$	3,56	ps/(nm.km)
$\Delta\lambda$	1	nm
L, min	0,002	km
L, max	0,072	km
D_{PMD}	0,2	ps/ $\sqrt{\text{km}}$

Table 5. Result of Rise Time Budget Analysis

	Rise time (ns)		Rise time allowed (ns)
	min	max	
Upstream (1310 nm)	0,223607	0,223607	0,56
	0,223607	0,223607	
Downstream (1550 nm)	0,223607	0,223610	0,28
	0,223607	0,223610	

Network Safety

ITU-T Recommendation G.983.5 describes the functions needed to extend GPON to enable survivability and network protection enhancements for delivering highly reliable services (Keiser, 2006). Generally, there are 3 forms of protection: type A (spare feeder fiber), type B (duplicate OLT), and type C (duplicate PON). Another standard, the ITU-T Recommendation G.984.1 (ITU-T, 2008) describes the use of protection switching. This allows several different types of PON configurations, including redundancy of links and equipment for network protection (Ab-Rahman et al., 2022; Keiser, 2006).

Network protection refers to the prevention and action plans to ensure the transmission continues both ways to and from the users in case there is a network

faulty. There are two types of network faulty, i.e., link faulty and node faulty. The network protection for link faulty is managed by leaving redundant fibers during the first installation. Figure 3 shows the 1:N

GPON protection procedure. In this type of protection, 1 spare cable is available for a group of users, completed with an optical switch on the source and destination side.

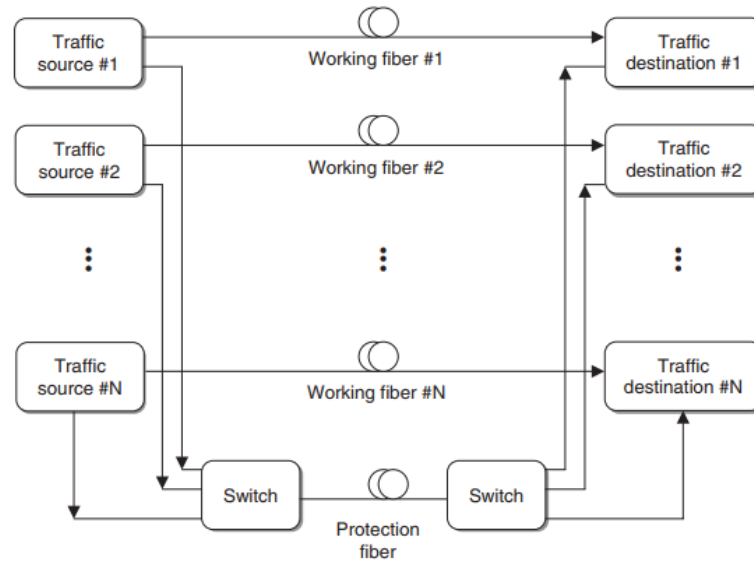

Figure 4. The 1: N GPON protection procedure (Keiser, 2006)

The 1: N protection is applied in the proposed FTTH in the form of redundant connection slots. Looking back to figure 3, there are 32 ODPs with a maximum capacity of 256 users while only 254 houses are currently listed in the designated area. The empty slots function as backup if the fiber link is damaged for any reason. The feeder cable installed to the ODC is also given extra 2 cores, which works as protection fiber in the 1:N scheme. Based on the fiber installation standards, there are also requirement for giving up to 10 meters in length for splice and connection slacks in bigger networks.

The determination of ODC capacity is also considered since there are various ODC capacity. In this design, ODC with 96 port capacity is used, because there are future developments to be considered. In the 96 port ODC, the allocated ports are 12 for feeder cables (input), 48 for distribution cables (output), and the rest are empty slots for development. There are at least 8 1:4

splitters. Table 6 shows the allocated ODC capacity and the current need in the proposed design. In the current design, there are 56 empty ODC slots for development if there are more users using FTTH links in the residence. New ODP and ONTs will have to be installed since its easier and cheaper but ODC allocation must be carefully considered.

Table 6. Allocation of ODC ports

Allocation	Max Capacity	Current design need
Port feeder	12	8
Port distribution	48	32
Port development	36	56
Total		96

CONCLUSION

A simple FTTH network based on a gigabit passive optical network scheme has been designed for use in a rural residential area. The 254 users are supported by optical fiber, 8 cores of feeder cable, going through ODC, ODP, and terminated in the ONT in

each user's home. The link power budget analysis and rise time budget analysis have been done and all the results are satisfactory according to ITU-T GPON standards. Network safety and protection are also considered by preparing redundant fiber cables.

Future work possibly developed is the simulation and analysis of performance by several other criteria, including bit error rate and signal-to-noise ratio. FTTH network security is also an interesting topic to analyze.

REFERENCES

- Abdellaoui, Z., Dieudonne, Y., & Aleya, A. (2021). Design, implementation and evaluation of a Fiber to The Home (FTTH) access network based on a Giga Passive Optical Network GPON. *Array*, *10*, 100058. <https://doi.org/10.1016/j.array.2021.100058>
- Ab-Rahman, M. S., Manaf, Z. Abd., Kaharudin, I. H., & Hwang, I.-S. (2022). Customer Edge Downstream Detection for Automatic Restoration Scheme in FTTH-PON Distribution Network. *Photonics*, *9*(8), 560. <https://doi.org/10.3390/photonics9080560>
- Ulfawaty, A. N., & Fausiah. (2019). Analisis Redaman pada Jaringan Fiber to the Home (FTTH) Berteknologi Gigabit Passive Optical Network (GPON) di PT Telkom Makassar. *AINET: Jurnal Informatika*, *1*(1), 21–27. <https://journal.unismuh.ac.id/index.php/ainet/article/view/2287/0>
- Awalia, W., & Pantjawati, A. B. (2018). Performance Simulation of Fiber to the Home (FTTH) Devices Based on Optisystem. *IOP Conference Series: Materials Science and Engineering*, *384*(1). <https://doi.org/10.1088/1757-899X/384/1/012051>
- Bakarman, H. A., Alsaqaf, A., Ba'Afiah, M., Baqhoom, F., & Baraja, M. (2021). Planning, Design and Simulation of a Network Access Based on FTTH-EPON for Hadhramout University. *Journal of Physics: Conference Series*, *1962*(1). <https://doi.org/10.1088/1742-6596/1962/1/012004>
- Fahmi, M., Nasaruddin, & Syahrial. (2018). Perancangan dan Analisis Kinerja Jaringan Fiber Optik Menggunakan Teknologi GPON pada Pemerintah Kabupaten Pidie Jaya. *KITEKTRO: Jurnal Online Teknik Elektro*, *3*(3), 1–5. <http://jurnal.unsyiah.ac.id/kitektro/article/view/11637>
- Hernandez, J. A., Sanchez, R., Martin, I., & Larrabeiti, D. (2019, June 1). Meeting the Traffic Requirements of Residential Users in the Next Decade with Current FTTH Standards: How Much? How Long? *IEEE Communications Magazine*, *57*(6), 120–125. <https://doi.org/10.1109/MCOM.2018.1800173>
- ITU-T. (2005). *ITU-T Rec. G.983.1 Broadband optical access systems based on Passive Optical Networks (PON)*.
- ITU-T. (2008). *ITU-T Rec. G.984.1 Gigabit-capable passive optical networks (GPON): General characteristics*.
- ITU-T. (2016). *ITU-T Rec. G.652 Characteristics of a single-mode optical fibre and cable*. <http://handle.itu.int/11.1002/1000/11>
- Jamal, N., Ulfah, M., & Irtawaty, A. S. (2021). Analisis Jarak Jangkauan Jaringan Fiber To The Home (FTTH) dengan Teknologi Gigabit Passive Optical Network (GPON) Berdasarkan Link Power Budget. *Prosiding Seminar Nasional Teknik Elektro Dan Informatika (SNTEI) 2021 Makassar*.

- <http://jurnal.poliupg.ac.id/index.php/sntei/article/view/2809>
- Keiser, G. (2003). *Optical Communications Essentials*.
- Keiser, G. (2006). *FTTX Concepts and Applications*.
- Nofrizal, Marsa, A. R., & Zulkifli. (2022). Analisis Kinerja Jaringan Internet Menggunakan Mikrotik dengan Backbone Fiber Optik dengan Metode QoS. *JTKSI (Jurnal Teknologi Komputer Dan Sistem Informasi)*, 5(2), 141–147. <https://ojs.stmikpringsewu.ac.id/index.php/jtksi/article/view/1164>
- Ridho, S., Isya, A., Yusuf, N. A., Andra, S., Nikken, D., Sirin, S., & Apriono, C. (2020). Perancangan Jaringan Fiber to the Home (FTTH) pada Perumahan di Daerah Urban (Fiber to the Home (FTTH) Network Design at Housing in Urban Areas). In *Jurnal Nasional Teknik Elektro dan Teknologi Informasi*. (9)1.
- Santika, M. E., Utami, E. Y. D., & Murtianta, B. (2016). Analisis Perencanaan Jaringan Akses Fiber-to-the-Home Berdasarkan Teknologi Gigabit Passive Optical Network (GPON) di STO Banyumanik Semarang. *Techné Jurnal Ilmiah Elektroteknika*, 15(2), 111–119. <https://ojs.jurnaltechne.org/index.php/techne/article/view/146>
- Sugumaran, S., Lakshmi, D. N., & Choudhary, S. (2021). An Overview of FTTH for Optical Network. *Lecture Notes in Electrical Engineering*, 721 LNEE, 41–51. https://doi.org/10.1007/978-981-15-9938-5_6
- Tarigan, J. S., Sugesti, E. S., & Astuti, R. P. (2022). Analysis Of Optical Fiber Backhaul Network Design For Passangers' Lte Communication Service On Jakarta-Surabaya High Speed Train Pekalongan-Cepu Section. *E-Proceeding of Engineering*, 9(2), 331–339.
- <https://openlibrarypublications.telkomuniversity.ac.id/index.php/engineering/article/view/17569/0>
- Utami, A. R., Rahmayanti, D., & Azyati, Z. (2022). Analisa Performansi Jaringan Telekomunikasi Fiber to the Home (FTTH) Menggunakan Metode Power Link Budget Pada Kluster Bumi Nirwana Balikpapan Utara. *CIRCUIT: Jurnal Ilmiah Pendidikan Teknik Elektro*, 6(1).